



# Sikorsky Archives News

October 2019

Published by the Igor I. Sikorsky Historical Archives, Inc. M/S S578A, 6900 Main St., Stratford CT 06615

## Igor Sikorsky Solves “The Helicopter Problem”



*Igor Sikorsky's VS-300 demonstrator refined the world's most common helicopter configuration.*

**W**hen Igor Sikorsky first flew his VS-300 helicopter on September 14, 1939, he made vertical flight discoveries that shaped helicopters to this day. Most rotorcraft built since use the single main lifting rotor and single tail anti-torque rotor layout he perfected to achieve efficient hover and cruising flight. Making the helicopter

safe and responsive took four years of continuous engineering, manufacturing, analysis, flight test and refinement. The talent, ingenuity, and persistence of Sikorsky and his team ultimately sustained the company that carries his name. The VS-300 legacy still serves the world – so far this year alone, Sikorsky helicopters have saved more than 800 lives.

Visit us at [Sikorskyarchives.com](http://Sikorskyarchives.com)

Contact us at [iisha@snet.net](mailto:iisha@snet.net) 203.386.4356

Rotary wings for vertical takeoff intrigued young Igor Sikorsky in his native Russia. However, without engines of sufficient power, the H-1 and H-2 coaxial helicopters Sikorsky built in 1909 and 1910 could not fly with a pilot aboard, and the young engineer and pilot re-focused on fixed-wing aircraft.

Later, in America, as engineering manager of one branch of the Vought-Sikorsky Aircraft Division within United Aircraft Corp. (UAC), Igor Sikorsky told UAC management of his H-3 direct-lift concept in a paper called *The Helicopter Problem*. In 1930, he wrote, "The most important problem to be solved in order to achieve complete success and to build a directly useful machine appears to be in the question of proper stability and control."

Igor Sikorsky recognized the achievements of earlier helicopter pioneers. According to his son Sergei, "He said that it was the Focke-Achgelis Fa-61 which was in his opinion the first practical helicopter."



*Igor Sikorsky considered Germany's Focke Achgelis FA-61 the world's first practical helicopter.*

The German FA-61 with side-by-side rotors was the forerunner of bigger wartime transports halted by Allied bombing. Likewise in Germany, Flettner produced a wartime synchropter overtaken by events. "However, the VS-300 was the machine that perfected the single-main-rotor-plus-tail-rotor configuration," explained Sergei Sikorsky. "Today, about 95% of all the helicopters built since 1939 have followed the VS-300 configuration."

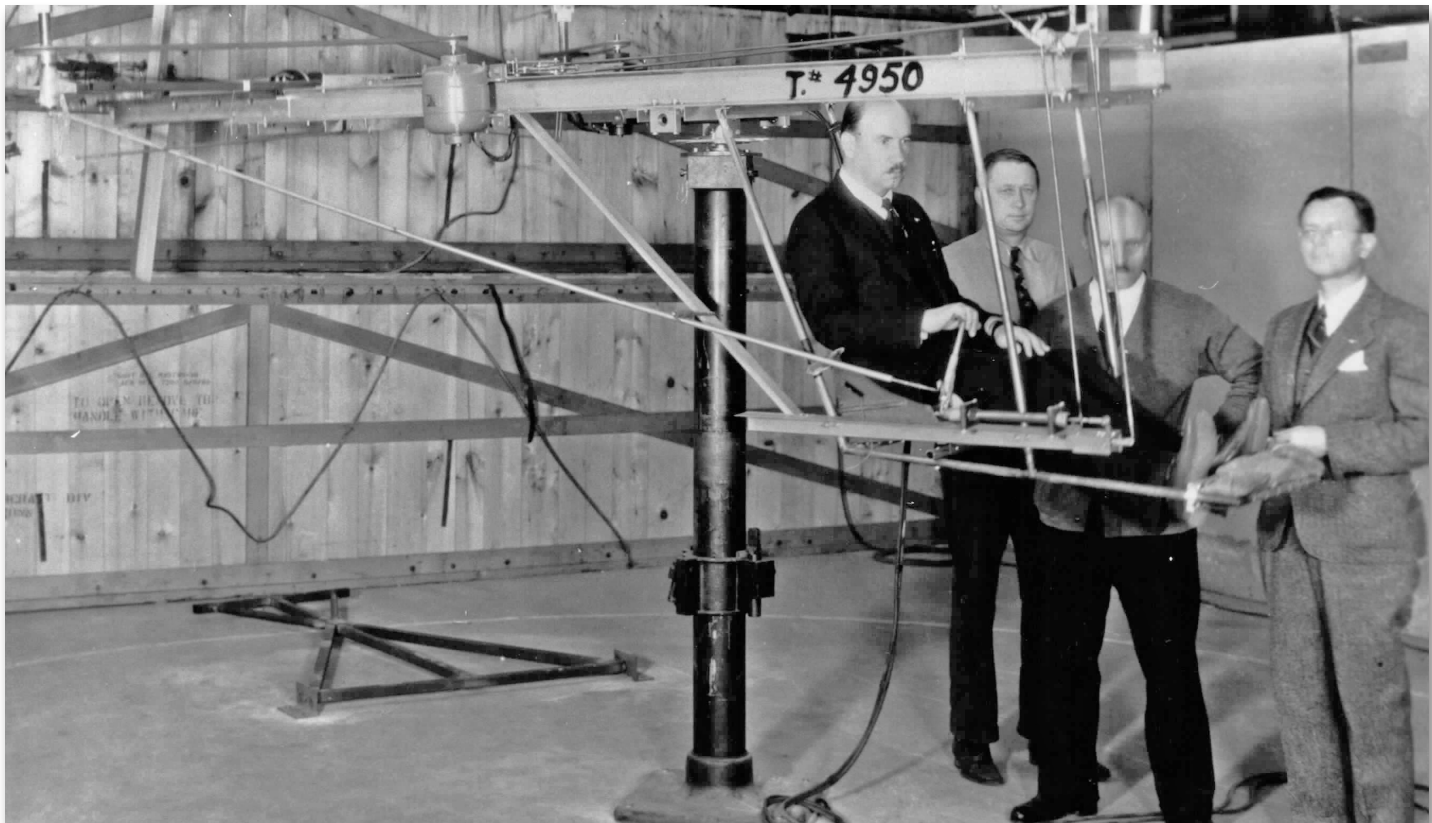

*In the first phase of Sikorsky's helicopter research, his team built a simulator with three rotors driven by a five hp electric motor. From left to right, Igor Sikorsky, Michael Buivid, Bob Labensky and Michael Gluhareff.*

The promising first-phase investigations provided the technical basis for a helicopter. With flying boat orders running out, the Sikorsky Division of UAC was near closing. Igor Sikorsky gained the support of corporate vice president Eugene Wilson for a direct lift demonstrator – the Vought-Sikorsky VS-300 (later designated Sikorsky S-46). Sergei Sikorsky acknowledged, “He knew that he had to build a successful helicopter because otherwise Sikorsky would be folded into the Chance Vought Division at another time.”

Sikorsky’s bid for second-phase funding in May 1939 included a request that he retain his engineers and craftsmen. “There were a lot of good, serious individuals connected,” said Sergei Sikorsky. “Eight or ten men I remember as the core group of the VS-300. It was understandable they were also the core group on the prototype XR-4.” The wartime XR-4 (S-47) attained production as the R-4 and HNS-1 for the U.S. Army, Coast Guard, and Navy.

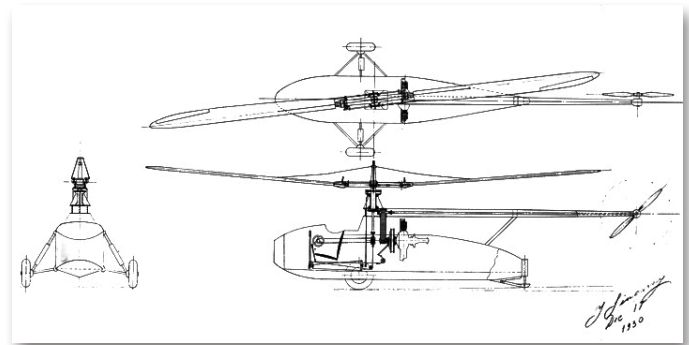

*Igor Sikorsky filed a US patent application in 1930 for a direct lift aircraft with a single overhead lifting rotor and a single tail anti-torque rotor.*



*Sikorsky’s VS-300 team went on to work on the company’s first production helicopter, the R-4. Left to right, Frank Gregory, Bob Labensky, Serge Gluhareff, Edward Walsh, Les Morris Front: Ralph Alex, Michael Buivid, George “Red” Lubben, Miles ‘Bud’ Roosevelt Dolph Plenefisch.*

The core VS-300 team started with Igor Sikorsky and two or three Russian confidantes and grew to include others who brought proven skills to the rapid prototyping effort. Experimental engineer Boris “Bob” Labensky joined Igor Sikorsky developing the S-29 fixed-wing transport and according to Sergei Sikorsky could “build any mechanical device you needed out of spare scrap.” Fellow Russian Navy and S-29 veteran George Buivid ran the experimental shop in Stratford. S-29 pilot Alex “Al” Krapish was a self-taught engineer who oversaw VS-300 assembly and maintenance.

Igor Sikorsky’s cousin, Igor Alexis “Prof” Sikorsky and fellow aerodynamicist Alexander “Nick” Nikolsky led VS-300 rotor development. Brothers Serge and Michael Gluhareff filled out the senior engineering staff. Sergei Sikorsky noted, “Michael was an aerodynamic genius. . . . At first, he was not too happy with the helicopter but eventually became a strong supporter.” German master mechanic Adolph Plenefish built the helicopter simulator and later the VS-300. Graduate engineer George “Red” Lubben preferred the VS-300 workshop to a drawing board and was subsequently drafted into the U.S. Coast Guard where he helped design the first helicopter rescue hoists. Mechanic Henry “Hank” Wirkus went on from the VS-300 project to the Coast Guard and Army to work on early helicopters.

The first VS-300 configuration to fly was a simple, open airframe with a sheet metal tail boom. The three-bladed 28 ft diameter main rotor with full cyclic pitch control was controlled by a cyclic pitch stick on the centerline and a collective pitch wheel on the pilot’s right. The main rotor blades used a symmetrical NACA airfoil built around an aluminum spar with spruce, mahogany, and balsa laminations. Sikorsky licensed articulated rotor head technology developed by Harold Pitcairn and inherited the low hinge offset and limited control power of the autogyro. A single-bladed, counter-balanced anti-torque rotor 40

in. in diameter commanded yaw via a single foot pedal. A short shaft connected the main rotor to a simplified transmission and 75 hp Lycoming engine.

The first tethered VS-300 flight by Igor Sikorsky in September 1939 lasted seconds and rose inches off the ground. Sikorsky kept early untethered flights brief and maneuvers conservative. “He knew he was teaching himself to fly the helicopter at the same time he was testing the helicopter,” explained Sergei Sikorsky. “He told me if something happened and the helicopter crashed, tradition blamed either the chief engineer or chief test plot. He said, ‘Because I was both, I’d be held responsible no matter what happened.’”

## Fly-Fix-Fly

First flight in Stratford began a continuous cycle of VS-300 discoveries and changes. Sergei Sikorsky recalled, “I would say the high point, according to my father, was that very first lift-off and two or three weeks later in December 1939 as he realized he had a machine that could fly.” Years later, after a busy day at the Paris Air Show, Igor Sikorsky reflected on the first helicopter flights and confided to his son, “Vibration was fierce; control was marginal; stability was non-existent -- that was his private assessment many years later of the VS-300 in the hover.”

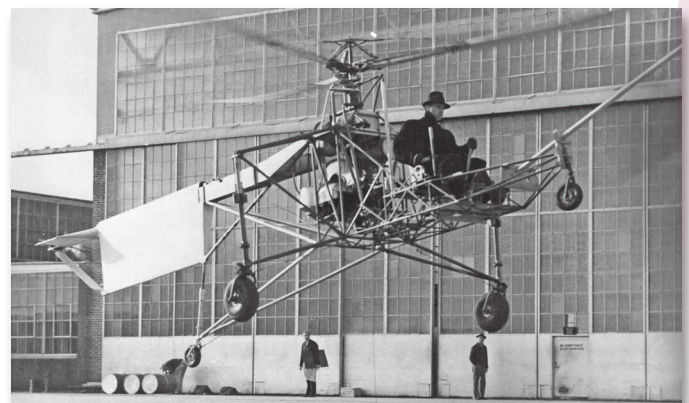

*VS-300 aerodynamicist Serge Gluhareff shared test piloting duties with Igor Sikorsky.*

Subsequent flights by Igor Sikorsky and Serge Gluhareff encountered rotor control lag that caused the VS-300 to roll left as it tried to fly straight. The effect was eventually overcome with incremental changes to the rotor swash-plate, but like many new helicopter challenges, answers were developed by trial and error. By November 1939, the VS-300 had a collective pitch stick to the left of the pilot and dual tail rotor pedals.

A wind gust caused the VS-300 to tip and crash on December 9, 1939, and work began on rebuilding the helicopter. In its second configuration, the VS-300 abandoned main rotor cyclic control for aircraft pitch and roll. Two horizontal tail rotors were added on outriggers to determine attitude and bank. The second configuration with its longer nose, welded-tube tail, and shock-absorbing landing gear flew on March 6, 1940. It flew before a crowd in Bridgeport that May, and Igor Sikorsky earned the first helicopter pilot's license issued by the state of Connecticut.

The agile display of the VS-300 in hover, sideways, and rearwards flight was witnessed by UAC executive vice president Eugene Wilson who later approached Igor Sikorsky and said, "Mr. Sikorsky, interesting machine. I have not seen it fly forward yet." The engineer-pilot answered, "Forward flight, Mr. Wilson, is a minor technical problem we have not solved yet." According to Sergei Sikorsky, "The problem was they underestimated the power of the lead-lag phenomena when flying forward. They had very, very primitive rubber washer-snubbers to control the fore and aft movement of the rotor blades. It was shortly after that that they put the hydraulic dampers horizontally so they would dampen the forward and the rearward motion of the rotor blades as the helicopter flew forward. That was one of the major solutions tested on the VS-300."

With successive lessons learned, the VS-300 team rebuilt their helicopter every two or three months. In July 1940, a 90 hp Franklin engine gave the VS-300 more power.



*The VS-300 used two horizontal tail rotors on outriggers to provide pitch and roll control.*

Trained by Igor Sikorsky, Army rotary wing project manager Capt. Frank Gregory flew the evolving helicopter. More flying introduced more changes. All three single-bladed tail rotors were replaced with bigger, two-bladed, hinged rotors. The horizontal tail rotor outriggers were subsequently raised 24 in. and stretched 24 in. to clear main rotor downwash. They were later inclined to tilt rotor thrust inward.

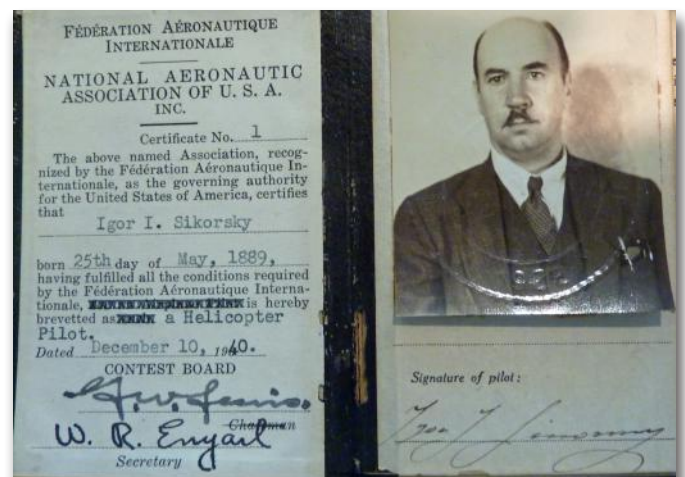

*Igor Sikorsky received the first helicopter license from the State of Connecticut Department of Aeronautics in May 1940 after a public demonstration of the VS-300. He was again recognized with the first helicopter pilot's license from the National Aeronautic Association of the USA in December 1940.*



# Sikorsky Development

## Configurations

I

Sept 39 – Feb 40



First Flight – September 1939

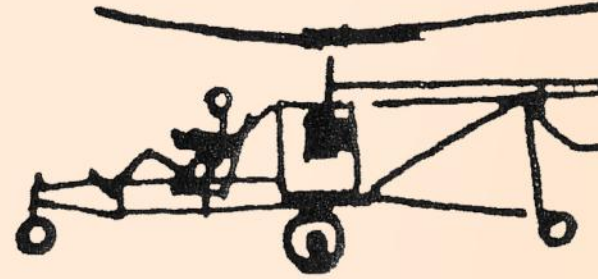

II

Mar 40 – Jul 41



May 1940



III

Aug 41 – Nov 41



November 1941

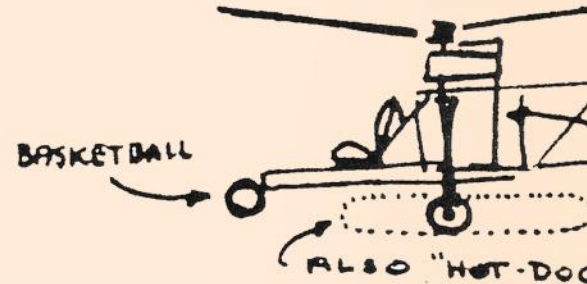

IV

Dec 41 – Oct 43



Final Flight – October 1943

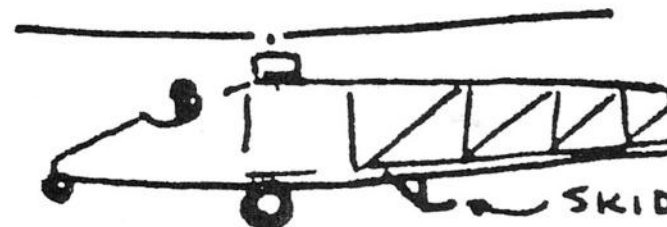

# Sikorsky VS-300 Tail Configurations

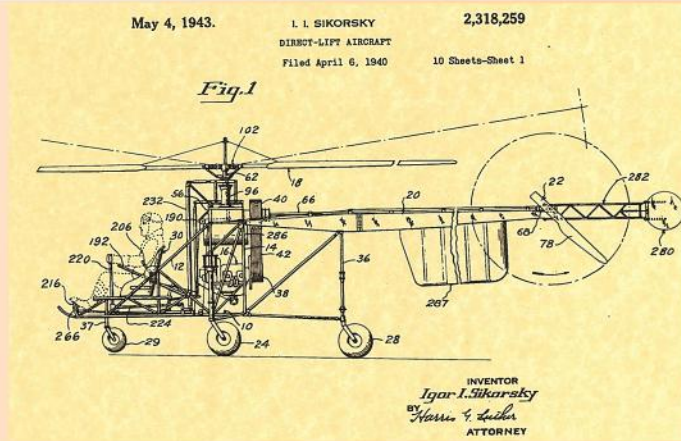
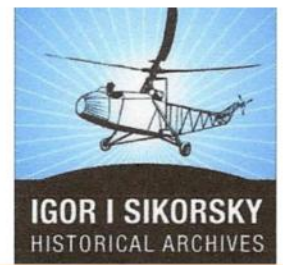

I. I. Sikorsky Patent  
Direct-Lift Aircraft  
Filed April 1940  
Awarded May 1943

## Various Tail Rotor Boom Configurations

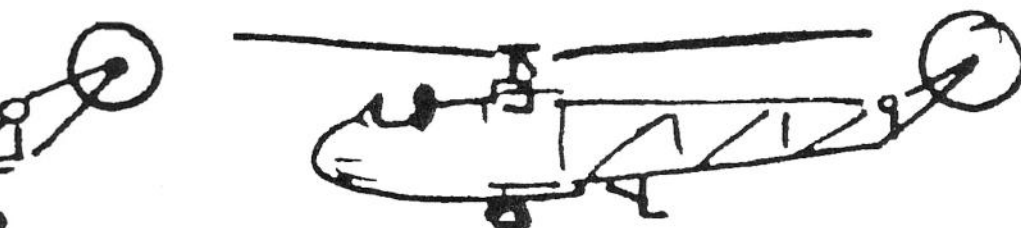
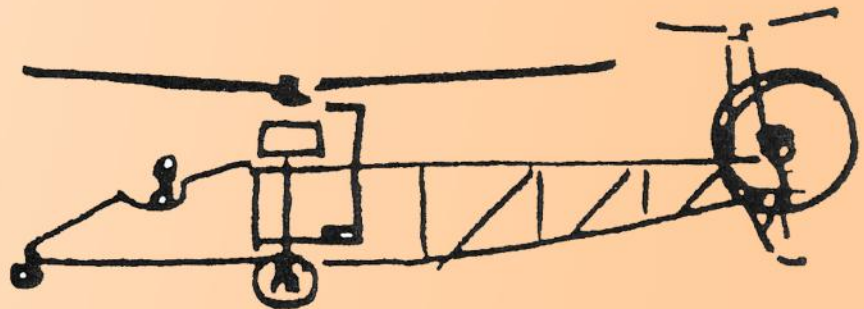
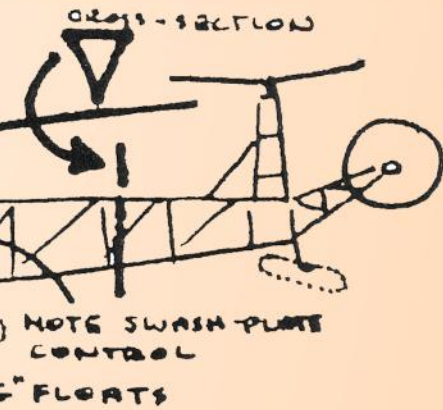
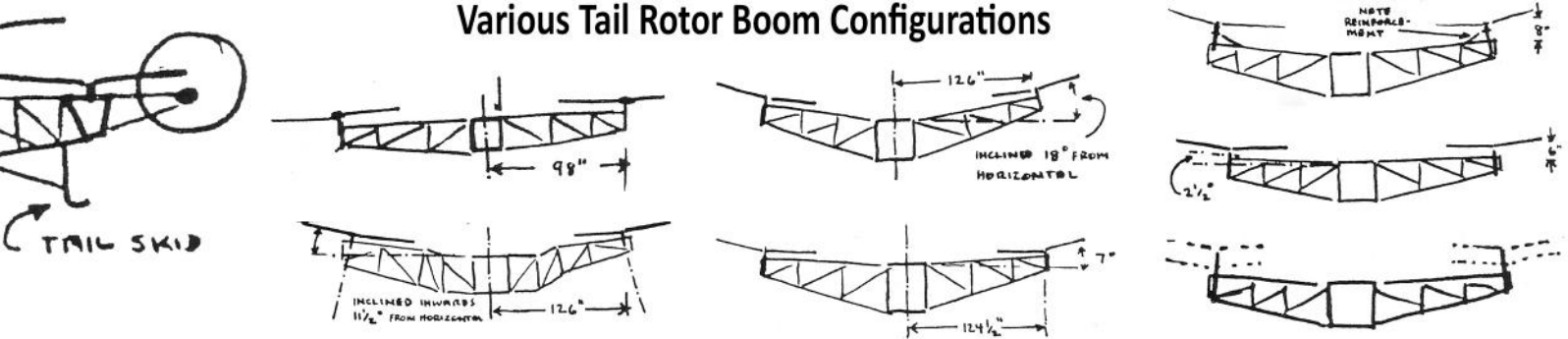

Sketches by Sergei Sikorsky  
For a copy of his original sketches  
see our website  
[Sikorskyarchives.com](http://Sikorskyarchives.com)



When an outrigger failed on October 14, 1940, the VS-300 crashed again. Igor Sikorsky emerged with minor injuries, and the team again rebuilt their helicopter.

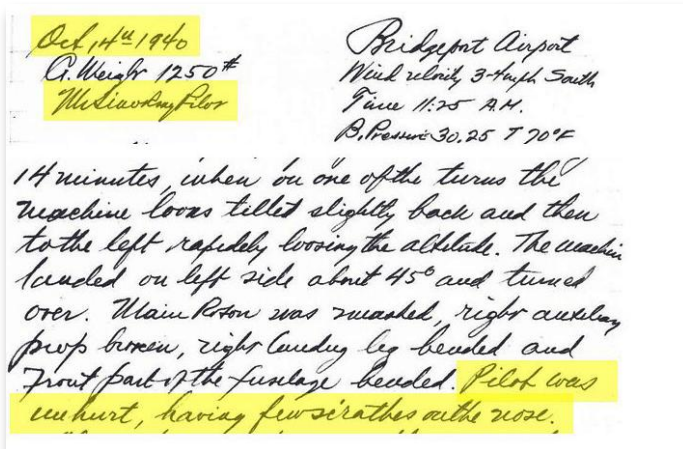

Igor Sikorsky recorded his crash in the VS-300 in October 1940, and his team rebuilt the demonstrator with lessons learned.

The VS-300 in its second configuration set a U.S. Helicopter Endurance Record on April 15, 1941 when it hovered for 1 hour, 5 minutes, 14.5 seconds. Weeks later, on May 6, 1941, Igor Sikorsky set an International Helicopter Endurance Record of 1 hour, 32 minutes, 26 seconds, besting the longest flight of the Fa-61.

The VS-300 made its first water landings with floats on the Housatonic River on April 17, 1941.



The VS-300 set a US Helicopter Endurance Record on April 15, 1941.

It crashed again in May 1941 with Igor Sikorsky at the controls, and UAC officials made it known they no longer wanted to risk their chief helicopter engineer on test flights. Sikorsky hired Connecticut aviation commissioner and experienced fixed-wing pilot Charles "Les" Morris to test and demonstrate the helicopter.

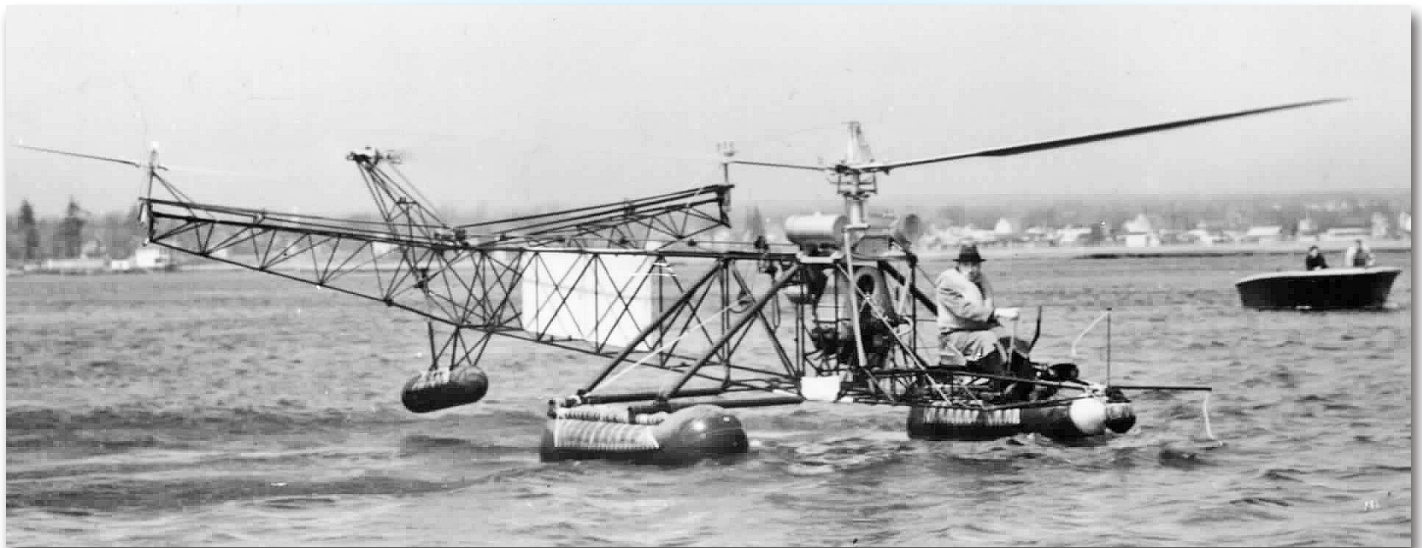

The VS-300 with floats made its first water landings and takeoffs in April 1941 with short pontoons, tail float, and 'basketball' nose bumper. It evolved with various float configurations, culminating in the VS-300A with long "hotdog" floats that eliminated the tail float.



In June 1941, the VS-300A configuration flew with cyclic control returned to the main rotor. Sergei Sikorsky explained, "Eventually, what they wanted to do at the urging of Colonel Frank Gregory was to eliminate all of the tail rotors and stick to just one anti-torque rotor and put all cyclic control into the main rotor for a slim fuselage."

Another amphibious demonstration with pontoons installed introduced pilot Serge Gluhareff and the rest of the team to ground resonance when the shaking helicopter jumped back into the air from a ramp and dropped about 10 ft to break its tail boom.

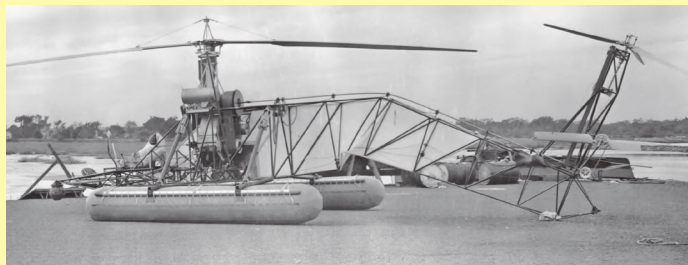

*Ground resonance caused the VS-300 to make a hard landing in June 1941.*



*Throughout its career the VS-300 had only rudimentary cockpit instrumentation.*



Army Air Corps Captain (later Colonel) H. Franklin Gregory became the first U.S. military helicopter pilot when he flew the VS-300. As the Army helicopter project officer, Gregory wrote the VS-300 technical evaluation that led the service to commit \$50,000 to the development of the XR-4. Gregory flew the first shipboard helicopter landings with the XR-4 in 1943.

On December 8, 1941, the VS-300A flew in its fourth configuration with a 30 ft diameter main rotor and single vertical tail rotor. Hydraulic dampers were added to control the lead-lag motion of the main rotor blades and eliminated serious vibration in forward flight. Sergei Sikorsky recalled, "In late December, Dad repositioned the oleos. The lead-lag vibration went away. In January, the XR-4 had oleos installed and began the Sikorsky R-4 program."

The Vought-Sikorsky VS-316, the military XR 4, with full azimuthal flight controls made its first flight on January 14, 1942, two weeks after the control problems were resolved on the VS-300A. Sergei Sikorsky observed, "When they decided to reposition the oleo dampers to horizontal lead-lag position, that was the last and final link in the engineering of the VS-300 single rotor concept." The change enabled the VS-300A to reach 80 mph. The research helicopter tried a two-bladed main rotor intermittently from October 1941 to February 1942, and while control proved satisfactory, two blades generated more vibration than three. Excessive damper loads from a three-bladed main rotor 30 ft diameter led the team to restore the original three-bladed main rotor, 28 ft diameter.

The VS-300A with a new rounded fabric nose underwent more control refinements, and drew more media attention. In the October 1942 issue



*The VS-300 flew successfully with a two-bladed main rotor, albeit with higher vibration levels.*

of *FLIGHTSHEET*, the publication of the Vought-Sikorsky club, editor Madeline Abell declared, "Sikorsky has produced a remarkable machine. It can rise straight up. It can descend vertically to the earth or to the water. It can climb, dive, swoop, turn, glide, dart, move sideways, forward, or backward. Which is the most astounding of its feats? The very fact that it is in existence, I think, and fortunate are those of us in contact with this, a new page in the history of aviation." Igor Sikorsky and his helicopter appeared on the cover of *LIFE* magazine in June 1943.

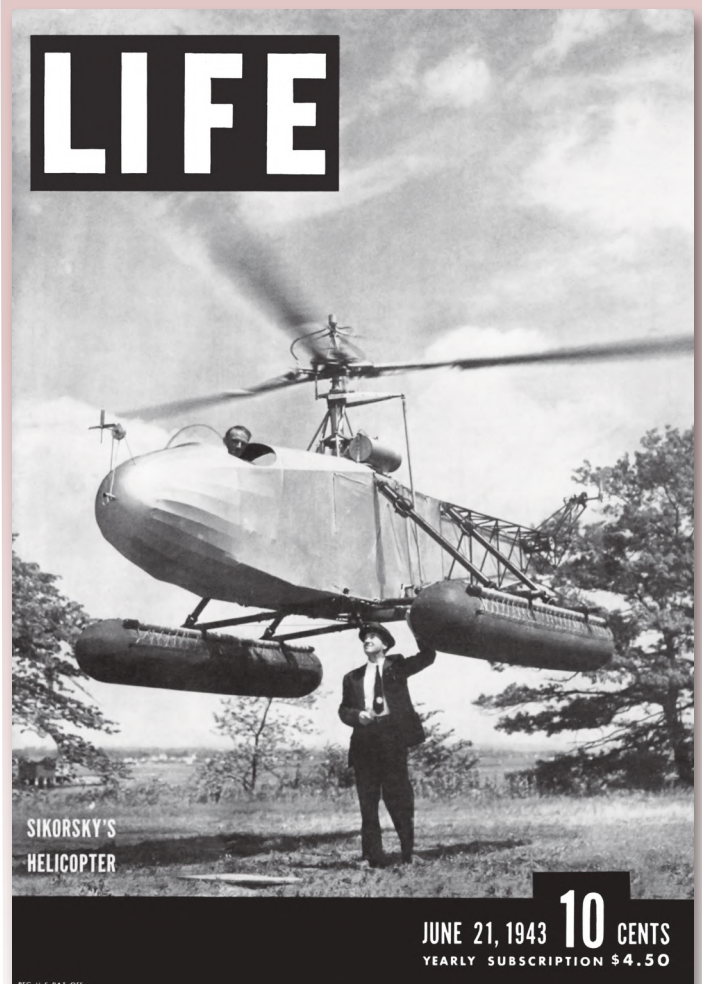

*The VS-300 and Igor Sikorsky shared the cover of the June 21, 1943 issue of LIFE magazine, part of the growing news media recognition of the helicopter.*

Also in 1943, Les Morris starred in a newsreel featuring the VS-300 in fanciful commuter service. Morris loaded groceries in the VS-300A nose basket, lifted off from a parking lot, landed at home in the suburbs, and flew off again

from his backyard demonstrating precise control with a future commercial aircraft. The VS-300A had a maximum takeoff gross weight of 1,325 lb and could carry a 284 lb payload.

Igor Sikorsky's helicopter demonstrator was accepted enthusiastically by Sikorsky's friend Henry Ford for display in the Edison Institute in Dearborn Michigan.

Over four years of intense development, the VS-300 logged 102 hours, 34 minutes, and 51 seconds flying time. Igor Sikorsky flew his direct-lift demonstrator for the last time on October 7, 1943 before he addressed the museum crowd. The helicopter remains on display in the Heroes of the Sky exhibit in the Henry Ford Museum of American Innovation.

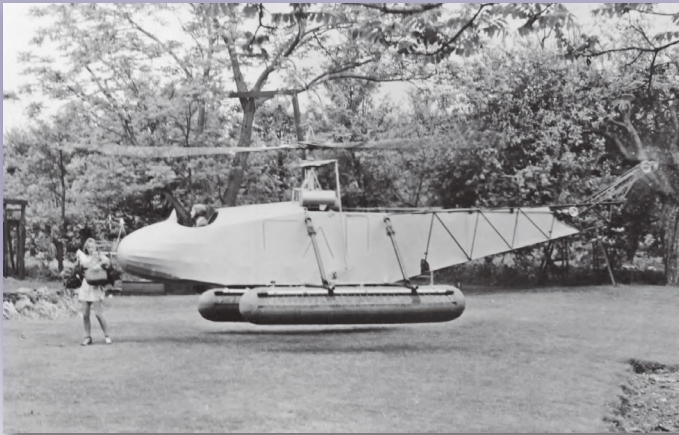

*Demonstration pilot Les Morris flew the VS-300 in a newsreel putting the helicopter through its paces in a suburban shopping run.*

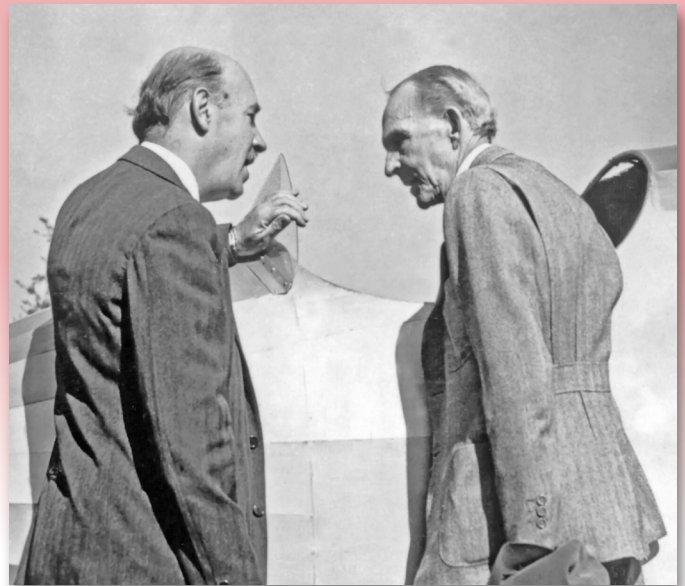

*Igor Sikorsky and automotive innovator Henry Ford.*



*Igor Sikorsky flew his VS-300 for the last time at a presentation ceremony at the Ford Museum in October, 1943.*



*The VS-300 remains on display in the Henry Ford Museum of American Innovation.*

## Help Us Preserve the Igor Sikorsky Heritage

**Igor I. Sikorsky Historical Archives**  
 MS S578A  
 6900 Main Street  
 Stratford, Ct 06615-9129

**Life Membership     \$250**  
**3 Year Membership   \$50**  
**1 Year Membership   \$20**

Please send a check or money order (do not send cash) payable to the Igor I. Sikorsky Historical Archives, Inc. or pay by Pay Pal (see our website [www.SikorskyArchives.com](http://www.SikorskyArchives.com) for instructions).

Name \_\_\_\_\_  
 Address \_\_\_\_\_  
 City \_\_\_\_\_  
 State \_\_\_\_\_ Zip \_\_\_\_\_  
 Phone \_\_\_\_\_  
 Email \_\_\_\_\_

**A 501(C)(3) Non Profit Organization**



*August 31, 2019 - Kyiv Mayor Vital Klitschko unveiled a monument to famous aircraft designer Igor Sikorsky near the Igor Sikorsky Kyiv International Airport.*



Prepared by Frank Colucci and John Bulakowski with graphic art and layout by Jodi Buckley.



*“The whole problem of the helicopter appears, therefore, interesting immediately as an engineering achievement and in the near future as a growing business proposition.”*

Igor Sikorsky – “The Helicopter Problem,” 1930

A copy of “The Helicopter Problem” is on our website

# Sikorsky Archives News

M/S S578A, 6900 Main St., Stratford CT 06615



Visit us at [Sikorskyarchives.com](http://Sikorskyarchives.com)