



# Sikorsky Archives News

April 2015

Published by the Igor I. Sikorsky Historical Archives, Inc. M/S S578A, 6900 Main St., Stratford CT 06615

## During The 1970 Decade Sikorsky Aircraft Had The Lowest Helicopter Production Rate In Its History!

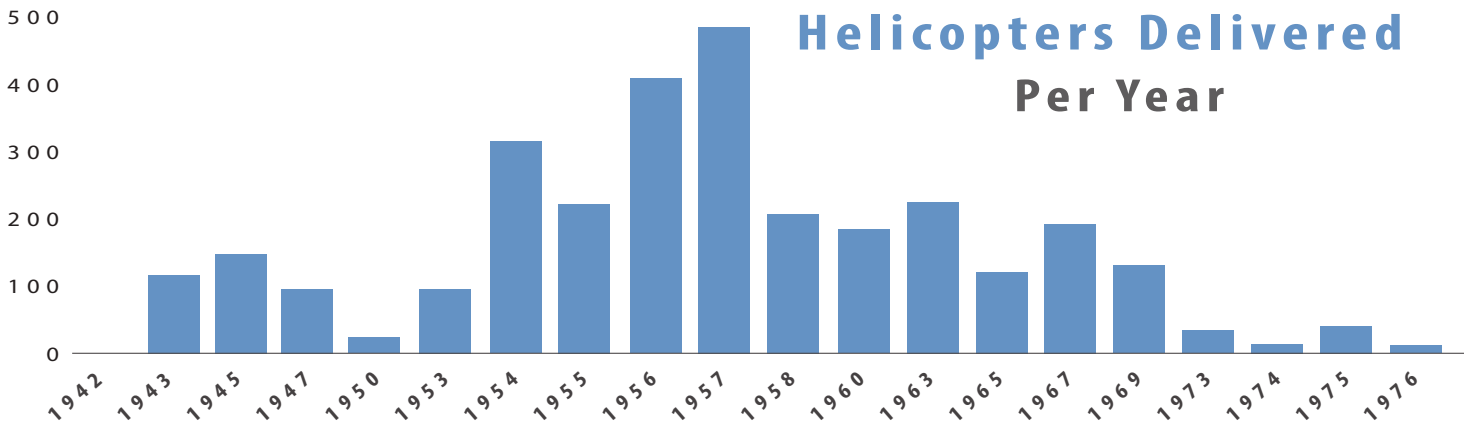

Igor Sikorsky is credited with creating the worldwide helicopter industry. Maintaining a competitive edge requires a continual search for new technology and innovations. This was readily demonstrated when the U.S. Army challenged the industry to develop a helicopter to meet the stringent requirements of the Utility Tactical Transport System (UTTAS) during the 1970s. Ray Leoni was the Sikorsky Program VP and authored the book titled, “Black Hawk, The Story of a World Class Helicopter”. The author discusses the Army’s requirements and the challenges the Sikorsky team faced. Ray documents some of the solutions and new innovations developed to win the UTTAS competition. This newsletter summarizes some of the new design features that led to Sikorsky aircraft being selected on December 23, 1976 as the winner of the production UTTAS contract. The S-70 Black Hawk and Seahawk series, the S-76, and the S-92 helicopters have reaped the benefits of the new design innovations. This newsletter is devoted to the history of the key features in the Hawk Family that produced the Sikorsky world class helicopters of today. This newsletter is part 3 of the series issued to date. 📧



(S-70) UH-60



(S-70) SH-60



S-76



S-92

Visit us at [Sikorskyarchives.com](http://Sikorskyarchives.com)

Contact us at [iisha@snet.net](mailto:iisha@snet.net) 203.386.4356



Harry J. Gray

## The Sikorsky S-70 (H-60) Black Hawk Program Started In The Early 1970s To Capture The Next Generation Army Helicopter Contract The Utility Tactical Transport Aircraft System (UTTAS)

Aerospace industry experts believed that Bell would easily capture the new army helicopter contract, because of their foothold in the Army with their UH-1 Hueys. Boeing Vertol was favored as second in line for the UTTAS prize. However, this did not deter Sikorsky from organizing one of its best teams to battle for the ultimate prize.

In the mid 1970s, the President of United Aircraft Corporation Harry Gray made changes to Sikorsky senior management by appointing Wesley A. Kuhrt to the position of Sikorsky Executive Vice President. Harry Gray enthusiastically provided continuous corporate support to the Sikorsky UTTAS team.



Wesley Kuhrt

One year later Wesley Kuhrt became president of the company and remained in that position until Sikorsky was awarded one of the two UTTAS prototype contracts, and the company began focusing on winning the production contract award. Wesley Kuhrt's background as Director of Research for the corporation and his accomplishments in developing advanced technologies made him the ideal candidate to lead Sikorsky at this critical period. At Sikorsky, Kuhrt led the application of advanced materials and aerodynamics technologies for the design of helicopter rotor systems.



John A. (Jack) McKenna

Ray Leoni was an experienced design and development engineer and was responsible for developing a winning design for the UTTAS competition. He was awarded the design patent for the Black Hawk helicopter.

John A. McKenna was the Engineering Executive VP and was assigned as the UTTAS Program Proposal Manager.

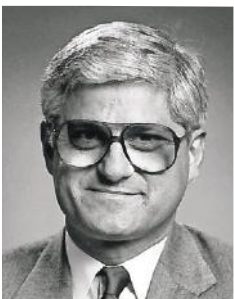

William (Bill) Paul

Bill Paul who later went on to be the president of Sikorsky Aircraft, was given the responsibility for developing and demonstration of new technology which could compete and win against the other helicopter companies competing for the UTTAS program, which was the major game in town at the time. The Sikorsky UTTAS team was comprised of all company disciplines such as Engineering, Manufacturing, Finance and Cost Control, Product Support, and many other key leaders as defined in Ray Leoni's book.

The decade of the 1970s was one of the most critical periods in the history of Sikorsky Aircraft. Had it not been for the foresight of the company leaders at the time, Sikorsky would have lost its leadership in the industry. In spite of the poor business climate, Sikorsky and UTC management decided to invest in the future by financing R & D programs applicable to helicopter technology. UTTAS was the Pot of Gold at the end of the rainbow. 🍀



Ray D. Leoni

The decade of the 1970s was one of the most critical periods in the history of Sikorsky Aircraft. Had it not been for the foresight of the company leaders at the time, Sikorsky would have lost ...

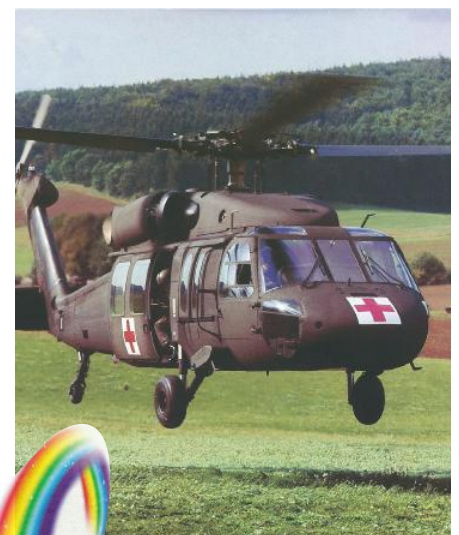



### UTTAS Engine Competition

The selection of the next generation engine to power the army UTTAS helicopter was a competition between General Electric and Pratt & Whitney. General Electric won the competition. The Sikorsky propulsion system design concentrated on integrating the engines for survivability, maintenance and minimum power losses.

*GE T-700 Engine >*



## The UTTAS Requirement For Air Transportability In The C-130 Cargo Aircraft Defined The Maximum Overall Size Of The Sikorsky S-70 (H-60)

This requirement impacted overall aircraft height, width, length and rotor diameters. The Sikorsky design team was faced with developing new approaches to achieve the required rotor lift performance. Smaller rotor diameters were developed with higher aerodynamic efficiencies, and an upward canted tail rotor to produce vertical lift was incorporated permitting a reduced diameter main rotor.

The initial aircraft test configuration was flown with a main rotor close to the top of the fuselage. It was purposely close to the fuselage in order to fit into the C-130 without removing the rotor. This configuration produced surprisingly high vibration levels exceeding the specification limits. This shock was not good news to the Sikorsky team. Upon further testing and analysis the aeronautical and dynamics experts concluded that the main rotor system was too close to the fuselage creating airflow interference which produced high aircraft vibrations.

The proposed solution to raise the rotor sufficiently to eliminate the airflow and rotor induced vibrations was a strategic management decision at the time. Fortunately, history has shown that it was one of many correct technical decisions Sikorsky management made to win the UTTAS contract. The raised rotor was still able to meet the stringent air transport requirement, because it benefitted from a cleverly designed two position rotor; high for flight and low for transport. 🍷

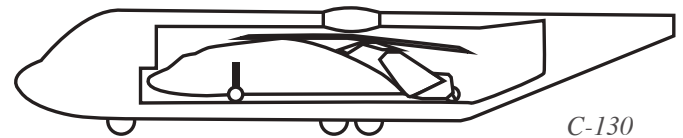

*C-130*



*Low Rotor*



*Raised Rotor*



*Boeing*



*Sikorsky*

## Key Technologies Developed At Sikorsky During The Decade Of the 1970s Played A Major Role In Sikorsky Winning The UTTAS Contract

The requirement for a high performance rotor blade is to build in a high spar twist angle and cambered airfoil section during the manufacturing process. Titanium was chosen for the spar because of its high strength, high stiffness and non-corrosive characteristics, but it presented unique manufacturing issues that were solved by the Sikorsky process engineers working together with designers. The development of the manufacturing processes started in the mid 1960s. The developed processes were used in the early 1970s to manufacture the blades for the S-65, S-70 and S-76. The process has been well proven and verified by excellent service experience. Sikorsky has continued blade improvements as shown below.



Bill Paul, Bob Zincone, and Lester Burroughs examining the titanium main rotor blade



S-70 (UH-60M) High Performance Titanium Main Rotor Blade with adhebral shape tip developed in early 2000s. Prior blades had no adhebral tip shape. Current production blades have composite spars.

### Low Maintenance Elastomeric Rotor Head

The rotor system elastomeric bearing technology originated at Sikorsky in early 1970 for the U.S. Marines to upgrade the CH-53 rotor system. Elastomeric bearings were designed to provide all blade flap, lag and pitch change motion with no lubrication required, and eliminates metal fatigue problems associated with the ball and roller type bearings previously employed in older model rotor systems. The elastomeric bearing approach reduces rotor vibrations and maintenance requirements.



S-65 (CH-53)  
Elastomeric  
Bearing Rotor  
Head in early  
1970



S-70 (H-60) elastomeric spindle assemblies installed in each main rotor hub arm of the one piece propeller hub

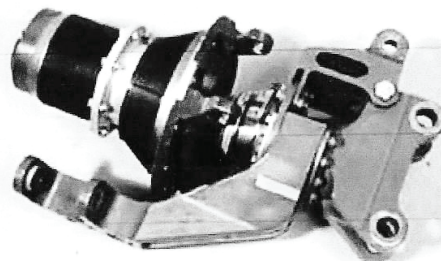

S-70 (H-60)  
Elastomeric  
Bearings and  
Spindle Assembly



## Additional Key Technologies Developed At Sikorsky During This Period Played A Significant Role In Sikorsky Winning The UTTAS Contract

### Bearingless Cross Beam Tail Rotor

The Black Hawk was the first production aircraft at Sikorsky to incorporate the cross beam tail rotor. Its name is derived by the simple construction of two graphite composite spars placed on top of each other at 90 degrees and bolted to the tail drive hub. The flexibility of the spar provides the blade pitch change requirements via the tail rotor control system.

The tail rotor for UTTAS is mounted on the pilot side of the fuselage and is a tractor pulling force on the tail pylon. This configuration provides ballistic tolerance. In the event of major tail rotor ballistic damage, it can separate from the pylon rather than impinge on and damage the airframe structure. The aircraft can then be landed safely.

*Test Cross Beam Tail Rotor on the S-61 aircraft*

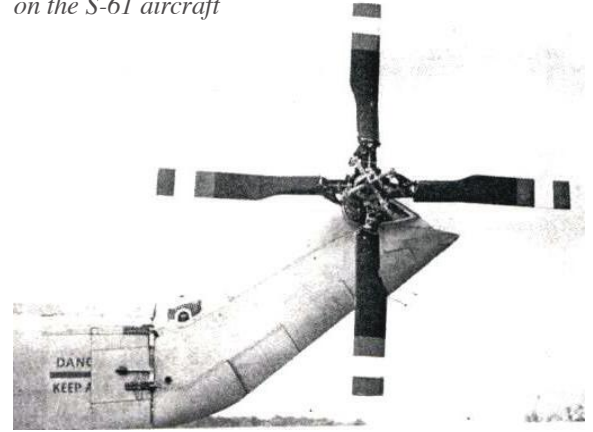

### Designed For Crashworthiness

The Black Hawk helicopter was the first U.S. military helicopter designed to operate in a low threat ground fire environment, and to have significant structural tolerance in mid to high intensity threat environments.

It was also the first military helicopter to be designed to protect flight crew and occupants in the event of crash landings. Field experience based on actual occupant reports has verified crashworthiness of the aircraft.

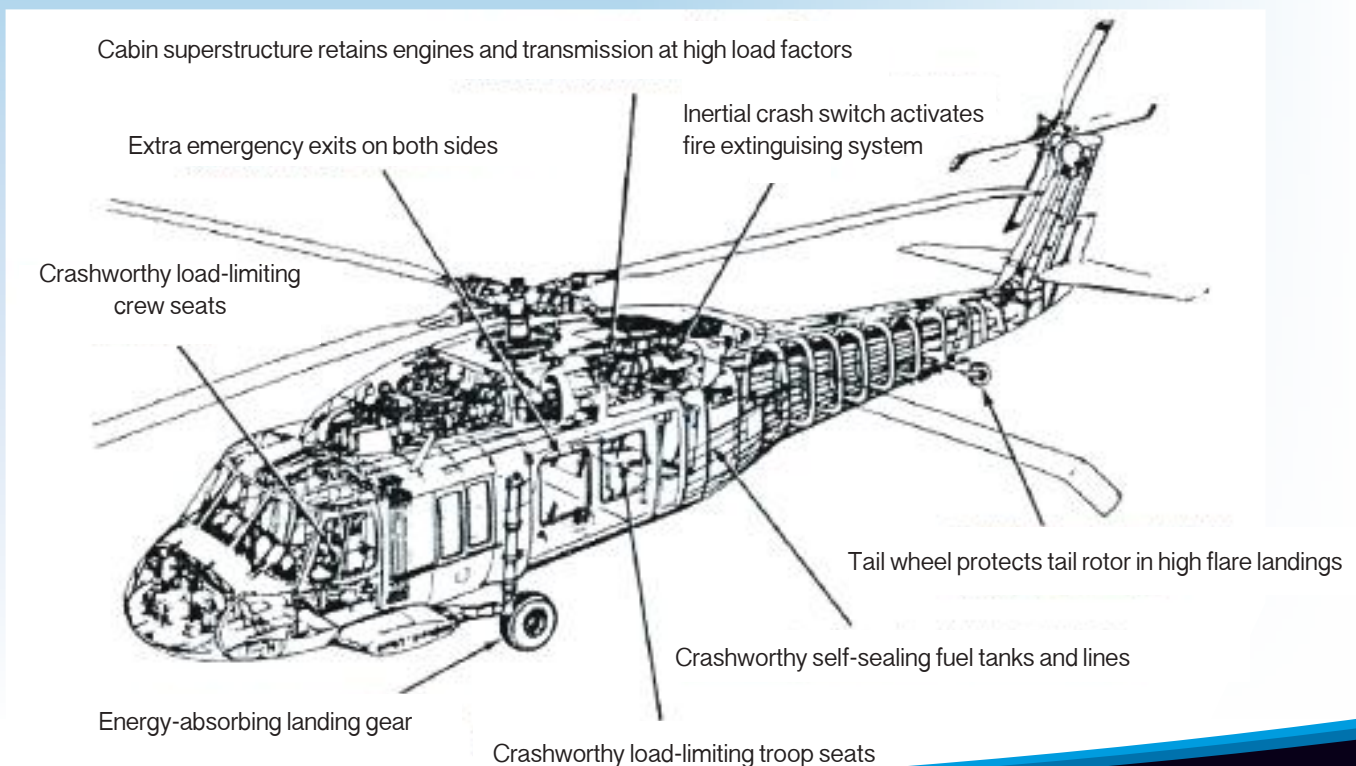

## U.S. Navy Selected Sikorsky To Build A Ship Based Model Named The SH-60B Seahawk

Two versions of the Seahawk family were eventually built. The SH-60B with a mid span tail wheel providing a smaller foot print for operation on small vessels. The other basic version was the MH-60S a Black Hawk type tail cone with a tail wheel with more space in the tail cone for equipment. The final two naval versions MH-60R and MH-60S cover the naval missions of ASW, search and rescue, anti-surface ship, on board resupply and mine sweeping missions. 🇺🇸



MH-60S



SH-60B



HH-60J

**HH-60J Jay Hawk** was developed for U.S. Coast Guard Medium Range Recovery Missions, Offshore Law Enforcement, Drug Interdiction, Aids to Navigation and Environmental Protection. Capabilities include 300 nautical mile radius of action, 45 minute search and rescue, Cruise at 146 knots, and compatible with Bear and Hamilton class cutters.



S-70A

**S-70A Firehawk** is a multi-mission Fire Fighting Helicopter. It has fixed provisions for a 1000 gallon removable tank, snorkel and water pump that can deliver 1000 gallons per minute. It has removable extended landing gear fittings when tank is utilized, thereby allowing for multi-mission capability.



**More than 40 Foreign Government Agencies Procured And Introduced Variations Of the H-60 Hawk Into Their Helicopter Fleet.**

There Have Been Over 4000 Hawk Helicopters Of Various Versions Delivered With A Total Accumulated Fleet Time Of Over 10 Million Flight Hours To Date.

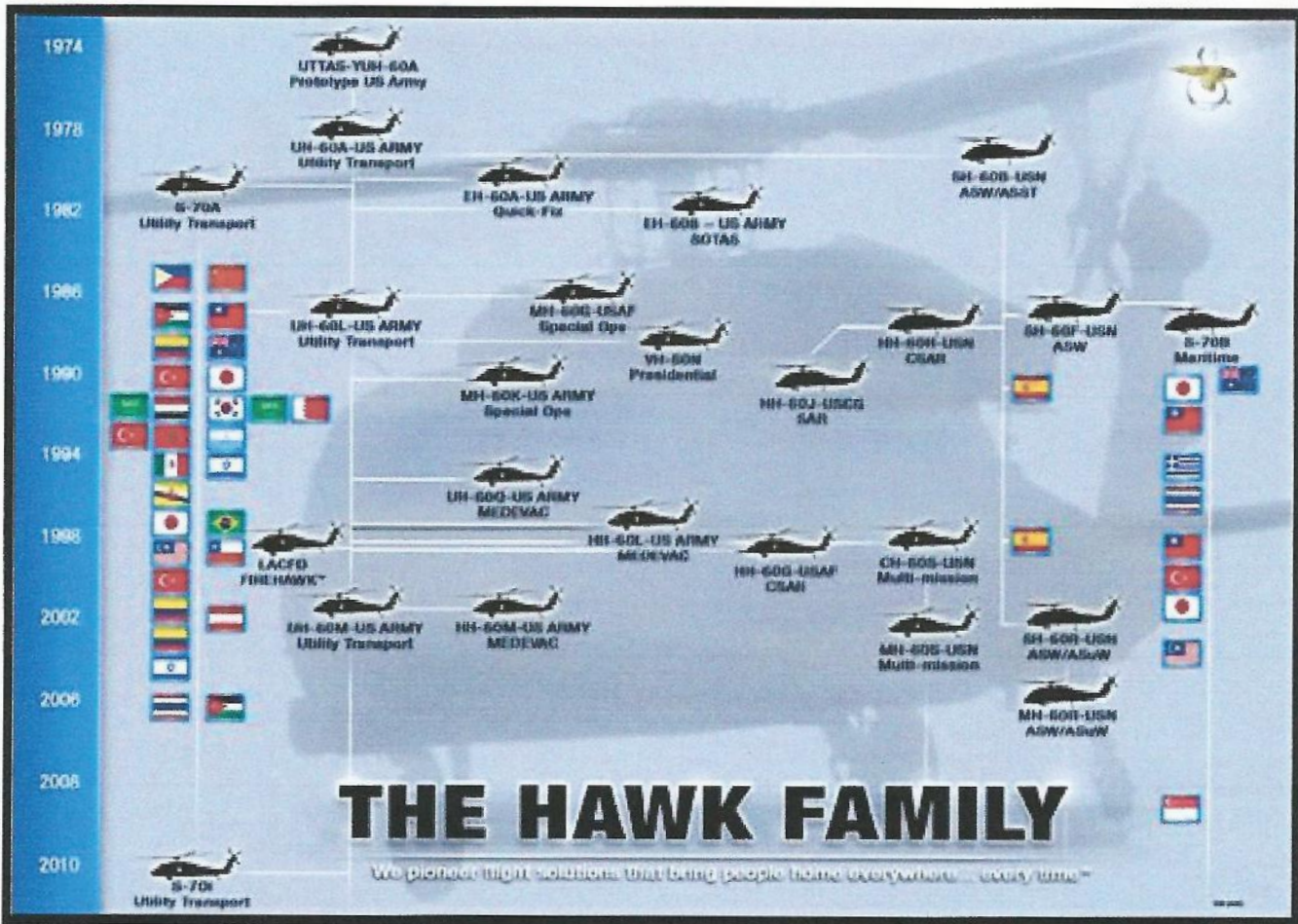

*Hawk salutes the Statue of Liberty*



*VH-60 Presidential Hawk is configured for government executive transport*

## Help Us Preserve the Igor Sikorsky Heritage

**Igor I. Sikorsky Historical Archives, Inc.**

MS S578A  
6900 Main Street  
Stratford, CT 06615-9129

**Life Membership \$250**  
**3 Year Membership \$50**  
**1 Year Membership \$20**



Please send a check or money order (do not send cash) payable to the Igor I. Sikorsky Historical Archives, Inc.

Name \_\_\_\_\_

Address \_\_\_\_\_

City \_\_\_\_\_ State \_\_\_\_\_

Zip \_\_\_\_\_ Phone \_\_\_\_\_

Are you interested in archiving?  Yes  No

**A 501 (C) (3) Non Profit Organization**

Newsletter designed and edited by Lee Jacobson and Archive members with graphic assistance by Edgar Guzman

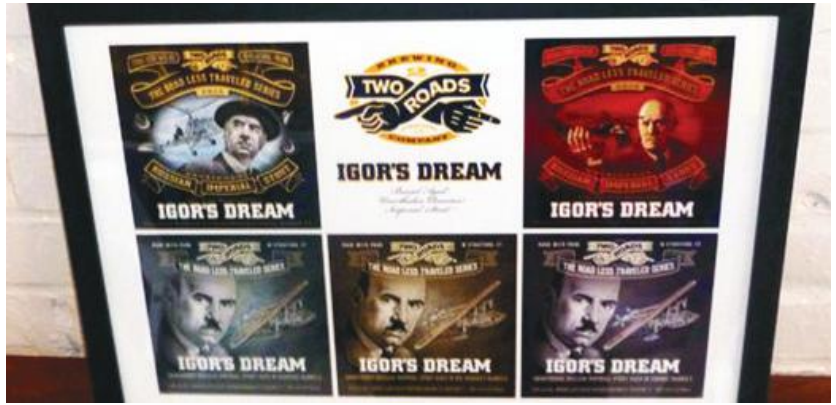

Stratford's Two Roads Brewery celebrated the third annual brewing of "Igor's Dream" beer. Igor Sikorsky Jr. and Nickolai Sikorsky were present signing bottles for first brew collectors.



"I have been hungry in America. I have known what it is to seek for work and not find it in America. But there was never a day during the hardest times that I lost hope in my planes or that I did not say aloud, 'Thank God I am here, a free man, breathing free air. No man can order what I do. If I fail I can try again!'"

– Igor Sikorsky

# Sikorsky Archives News

M/S S578A, 6900 Main St., Stratford CT 06615



Visit us at [Sikorskyarchives.com](http://Sikorskyarchives.com)