

# Sikorsky Archives News

Published by the Igor I. Sikorsky Historical Archives, Inc. M/S S578A, 6900 Main St., Stratford CT 06615

## Sikorsky Archives receives the John J. Schneider Award from American Helicopter Association International



Photo by Robert Flemming

**Harry Hleva and Sergei Sikorsky accepted the Award on behalf of the Archives at the AHSI convention in Phoenix, AZ in May.**



Igor I. Sikorsky  
Historical Archives Inc.

(203) 386-4218

(203) 386-4356

# July 2006

# S-55 SERIES HELICOPTER

## FIRST HIGH RATE PRODUCTION PROGRAM

The Sikorsky S-55 helicopter was the world's milestone helicopter in the 1950's. It was the aerial truck, commuter passenger carrier, air-sea rescue craft and early U.S.Navy anti-submarine warfare helicopter.

The company funded S-55 was designed, fabricated and flown in less than one year. After first flight in 1949, the U.S. Navy and Air Force procured the H04S/HRS and H-19. Army, Coast Guard and commercial procurement followed quickly. A total of 1,821 aircraft were produced between 1950 and 1961.

Sikorsky produced 1,281, and 547 were produced under license by Westland, SUD, and Mitsubishi.



Air Force H-19



Navy HO4S



Marines HRS



Air Force H-19

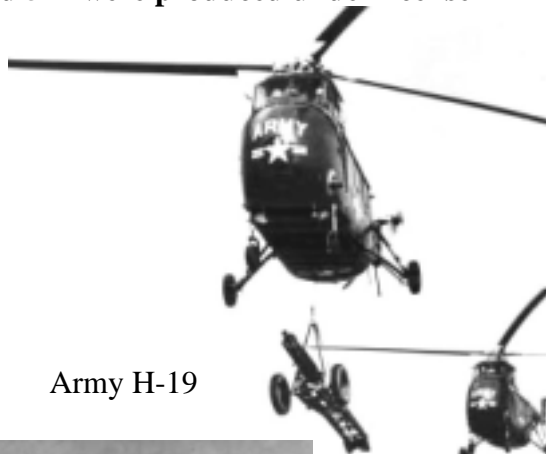

Army H-19

**Performance & Weights**  
Max. Speed 101 mph  
Cruise Speed 85 mph  
Range 405 st. mi  
Gross Weight 7200 lbs.

**Specifications**  
Seating: 2 pilots  
Passengers: 10  
Engine: P&W R1340 & Curtis Wright R1300  
Max HP: 600-700



Left: British Royal Navy Whirlwind performs a hoist rescue

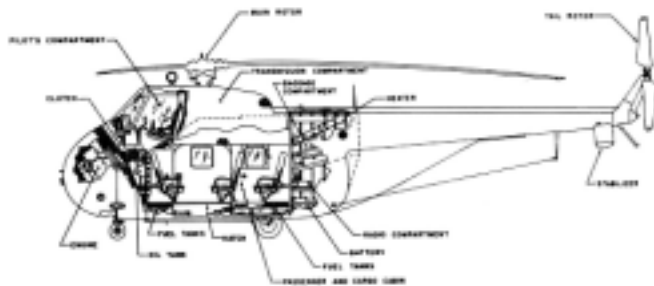

S-55 General Arrangement Drawing

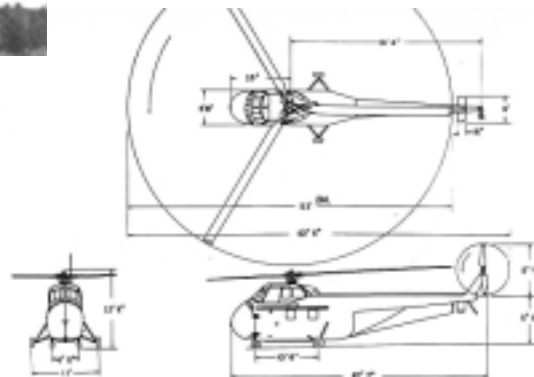

S-55 Three View

# First Trans Atlantic Crossing by Helicopter



Hop-a-long and Whirl-o-way arriving Prestwick, Scotland



The U.S. Air Force Air Rescue Service ferried two H-19s across the Atlantic Ocean by way of Labrador, Greenland, Iceland and Scotland to Wiesbaden, Germany. The two H-19s flew from Sikorsky to Westover Air Force Base in Massachusetts.

On July 15, 1952 the two aircraft, christened Hop-a-long and Whirl-o-way, started their long cross Atlantic journey to Germany. Harry Hleva and Edward Benham were the two Sikorsky representatives on the long adventurous trip. On July 31, Hop-a-long and Whirl-o-way arrived to a festive reception in Scotland. They were rushed to an air show in the Hague, Netherlands, and then to their final destination, Wiesbaden, Germany.

## S-55 Series Helicopter Firsts

- Main rotor blade twist
- Offshore oil support
- Anti submarine warfare
- Rotor blade tip rockets
- JATO (Jet Assist Take Off)
- Parachute retrieval by helicopter
- Aircraft retrieval by helicopter
- Trans Atlantic crossing
- Main rotor flapping hinge offset
- Pre tracked interchangeable blades
- Large cabin
- Scheduled passenger service
- S-55T Certified Turbine Helicopter



Above: Parachute Retrieval



Left: S-55 landing casualties near Hospital Ship during Korean War



**Workhorse  
for the  
Army and Marines**



The Army and Air Force H-19, and the Marines HRS saw extensive service during the Korean conflict with major roles in troop and cargo transport, search and rescue, and Medevac.



Above: : Marines Formation Flying

Above and Right: H-19 Sling Lift

Left: Marilyn Monroe waves to troops from the H-19 Korea, 1954



Army precision flying Square Dance Team



## Pioneers in Passenger and Cargo Service



LOS ANGELES AIRWAYS



NEW YORK AIRWAYS



SABENA - Belgium AIRLINES



NATIONAL AIRLINES



The S-55 was the first of the Sikorsky large cabin helicopters. The features that made it an excellent aircraft for supply and rescue operations during the Korean conflict allowed it to be a good utility and passenger carrying helicopter in the commercial market. The Sikorsky S-55 was the first helicopter FAA certified for scheduled passenger service.

## Pioneers in Helicopter Offshore Oil Support

Offshore oil and gas exploration in the Gulf of Mexico in the early 1950s created a requirement for helicopters to support the transportation needs of the industry. The first large cabin helicopter the S-55 was procured by Petroleum Helicopters (PHI) and entered service supporting the offshore oil industry in 1954. The pioneers in helicopter offshore oil support were PHI, Humble Oil and Chevron. This continues to the present with many operators utilizing the S-76 and S-92, the current industry favorites.



## JOIN THE ARCHIVES



Newsletter designed and edited by  
**Lee Jacobson**  
and **John Daniell**

Igor I. Sikorsky Historical Archives Inc.  
MS S 578A  
6900 Main Street  
Stratford, CT 06615-9129

Life Membership	\$125
3 Year Membership	\$25
1 Year Membership	\$10

Please send a check or money order (do not send cash)  
payable to The Igor I, Sikorsky Historical Archives, Inc.

Name \_\_\_\_\_

Address \_\_\_\_\_

City \_\_\_\_\_

State \_\_\_\_\_ Zip \_\_\_\_\_

Phone Number(s) \_\_\_\_\_

**Join today and help preserve the legacy of a visionary engineer.**  
*Have you changed your mailing address since you joined us? If so, please let us know.*

## Sikorsky Archives News

M/S S578 6900 Main St., Stratford CT 06615



Igor I. Sikorsky  
Historical Archives Inc.